

LED Module CK16D Series

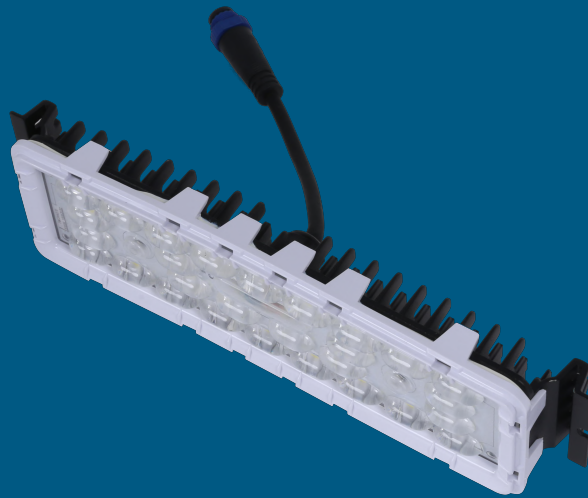

Specification

Working Environment: -40°C~+50°C

Storage Temperature: -40°C~+50°C

Relative humidity: 10%~90%RH

Typical Solder Point Temperature $T_s^{[1]}$: 55°C

IP Rating of LED Light Engine: IP68

Impact Protection Level: IK10

Color Temperature (CCT)^[2]: 3000K, 4000K, 5000K, 5700K

Main Material: Aluminum ADC12

Module N.W.: 0.49±0.03 kg

Note:

[1] Typical values of pad temperature is obtained based on the test power 40W
with ambient temperature 25°C.

[2] Efficacy of 3000K is 5% lower than other CCTs.

Features

- Customized LEDs from a world-leading supplier;
- Super long lifetime(Lumen maintenance);
- Multiple lighting distributions available;
- Wide applicability for complex situations;
- High versatility apply for all sorts of lamps retrofit.

Application

- Street lighting retrofit and application;
- Factory lighting retrofit and application;
- Tunnel lighting retrofit and application;
- Sports lighting retrofit and application.

Ordering Information

For example: CK16D-VBA-18 -2105-7040-CM

Module Model	Interface	Dimension of LEDS	Wire Standard	LED Qty	LED Model	Lens Model	Ra & CCT	LED Brand
CK16D	V: V-shape groove	B: 5050	A: CCC+VDE	18: 18PCS	1107 Type I Short	3125 25 DEG	7030 : Ra≥70 , 3000K	CM: Customized XX : Others
			C: PSE	28: 28PCS	2125 Type I Short	3140 40 DEG	7040 : Ra≥70 , 4000K	
			H: UL		2105 Type II Short	3160 60 DEG	7050 : Ra≥70 , 5000K	
			X: Others		2128 Type II Short	2190 90 DEG	7057 : Ra≥70 , 5700K	
					3106 Type II Short	2211 90x40 DEG		
					3108 Type II Short(V)	3504 80x35 DEG		
					2111 Type II Medium	3505 70x30 DEG		
					1113 Type III Short	2114 Square Lighting		
					2127 Type III Medium	2212 Sport Lighting		
					2109 Type III Medium	2123 Tunnel Lighting		
					2310 Lambert Type			

Performance

Module Model	Power (W)	Driving current (mA)	Input voltage (Vdc)	18pcs		28pcs	
				Efficacy (lm/W)	Lumens (lm)	Efficacy (lm/W)	Lumens (lm)
CK16D-VBA	30	600	40~54	168	5040	180	5400
CK16D-VBA	40	800	40~54	160	6400	175	7000

Note: Values shown are subject to ±5%~±8% tolerance; Cable default A type;

Efficacy above is based on calculated @92% power efficiency; Light efficacy of 3000K is 5% lower than other CCTs.

Dimensions

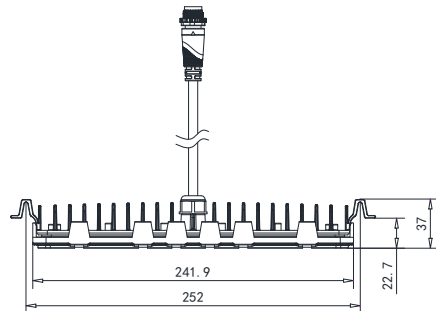
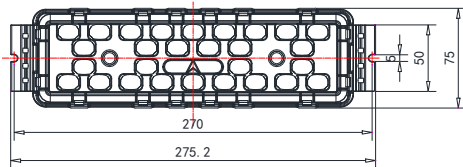

L (mm)	W (mm)	H (mm)
--------	--------	--------

275.2 75.0 37.0

*Tolerance: ±0.5mm

* Different lenses, the height will be 5% tolerance.

Available lens model

1107	1113	2105
2109	2111	2123
2125	2127	2128
3106	3108	

Dimensions

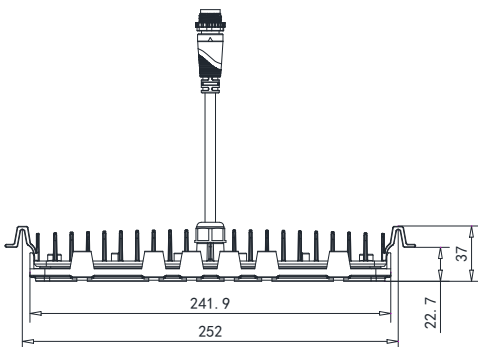
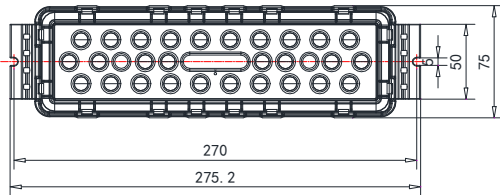
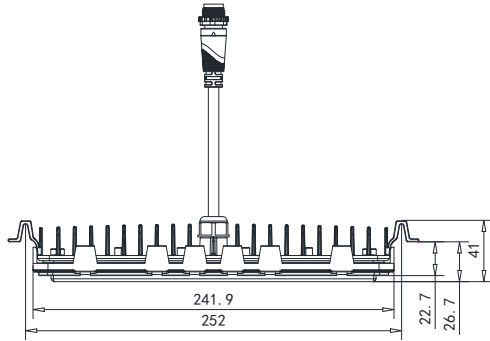
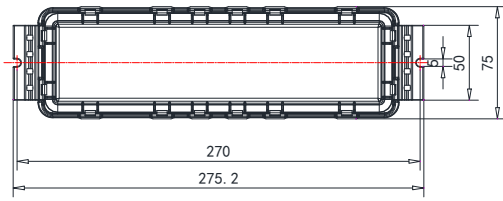

L (mm)	W (mm)	H (mm)
275.2	75.0	41.0

* Tolerance: ±0.5mm

* Different lenses, the height will be 5% tolerance.

Available lens model

2114	3505	3125
3140		

L (mm)	W (mm)	H (mm)
275.2	75.0	37.0

*Tolerance: ±0.5mm

*Different lenses, the height will be 5% tolerance.

Available lens model

2190	2211	2212	2310
3160	3504		

Package Information

L (mm)	W (mm)	H (mm)	Module pcs/carton (PCS)	Package weight (kg)
650	375	190	20	12.6

Values shown are subject to ±5% tolerance.

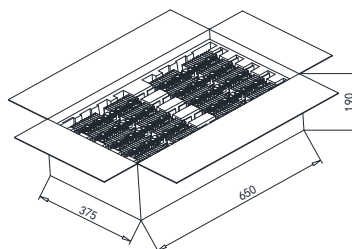
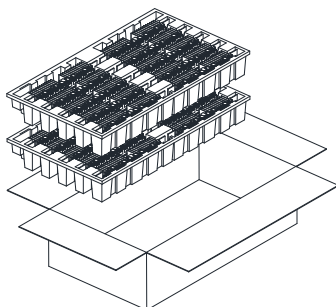

Lighting distributions



Version History

Change Date	Version	Description of Change		
		Item	From	To
20190422	Ver1.0	Data sheet release (new version)	/	/
20190617	Ver1.1	Improvement of Luminous efficiency	/	/
20190922	Ver1.2	Canceled 2414 and 5209 light distributions	/	/